

TOP VIEW

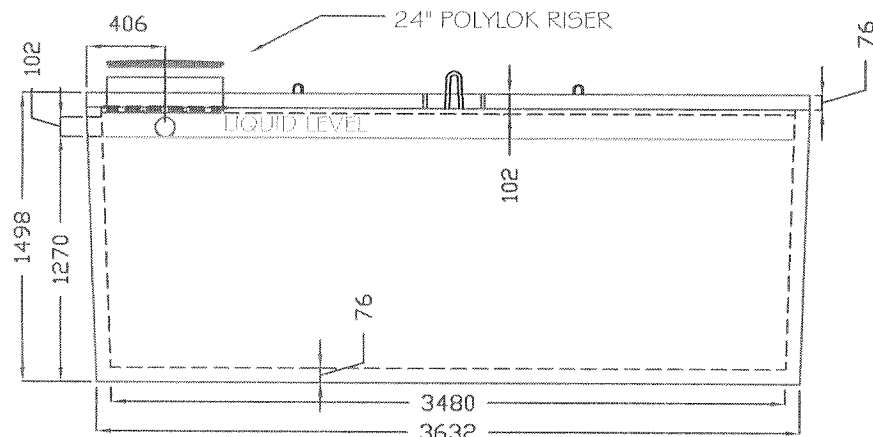

SIDE VIEW

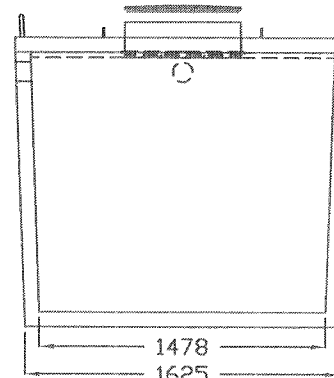

END VIEW

DIMENSIONS:

ALL DIMENSIONS IN MILLIMETERS.
+/- 10mm TOLERANCES ON ALL DIMENSIONS

CONCRETE:

STANDARD
STANDARD ACC(ACCELERATED STRIPPING)
10MPa STRIPPING STRENGTH
35 MPa @ 28 DAYS
SULPHATE RESISTANT
2.2 CUBIC YARDS(TANK)
1.1 CUBIC YARDS(LID)

REINFORCEMENT:

ALL REINF. HAS MIN. 25mm OF COVER

TANK:

WWF 6"x6" 6/6 (BOTTOM AND 36" OF SIDES)
1 - 10M RING (TOP)
4 - 10M VERTICALS (SIDES)

LID:

1 - 10M RING
4 - 10M BARS LONG WAY
2 - 10M BARS SHORT WAY

WEIGHT:

LID APPROX. 3473 LBS/1579 KG
TANK APPROX. 7901 LBS/3592 KG
ASSEMBLED APPROX. 11374 LBS/5171 KG

NOTES:

USE 3/8" X 8 1/2" PURPLE LIFTERS ON LID
JOINT SEALANT IS MASTIC SEALANT (CONSEAL CS-102)
(NSF APPROVED SEALANT AVAILABLE FOR POTABLE WATER TANKS)
TANK ASSEMBLED IN FACTORY
1.5M MAXIMUM BURIAL
INLETS ARE 4" POLYLOK PIPE SEALS
LID AND RISER ARE 24" DIAMETER POLYLOK



58 COOPER ROAD
ROSSLYN, ONT.
Phone: (807) 939-2655
Fax: (807) 939-1788

PRODUCT
1200 GAL/ 5500 L HOLDING TANK

JOB/PRODUCT CODE:
1200HTPR

CONTRACTOR:

SCALE:
N.T.S

DATE	INI.	DESCRIPTION
NOV 2013	MH	ORIGINAL DRAWING