

TOP VIEW

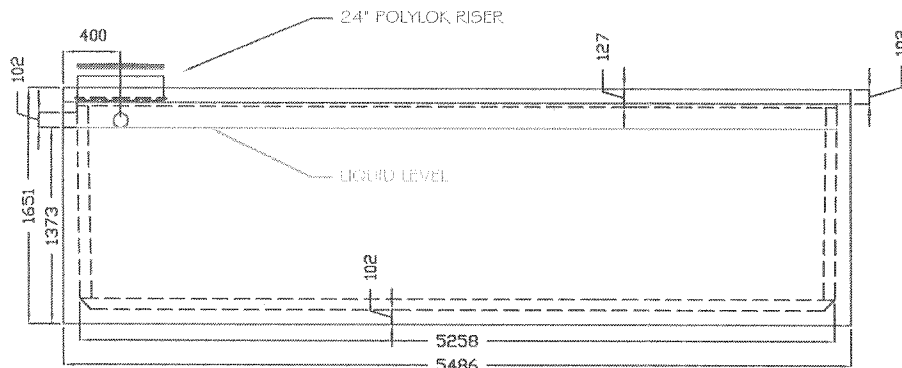

SIDE VIEW

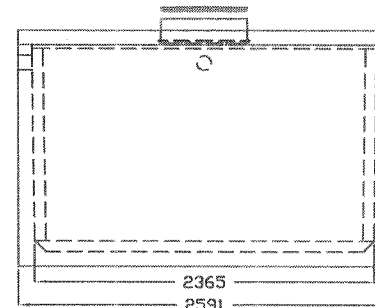

END VIEW

DIMENSIONS:

ALL DIMENSIONS IN MILLIMETERS.
+/- 10mm TOLERANCES ON ALL DIMENSIONS

CONCRETE:

STANDARD
STANDARD ACC(ACCELERATED CURING)
10 MPa STRIPPING STRENGTH
35 MPa @ 28 DAYS
C-1 EXPOSURE CLASS
SULPHATE RESISTANT
6.7 CUBIC YARDS (TANK)
1.9 CUBIC YARDS (LID)

REINFORCEMENT:

ALL REINF. HAS MIN. 25mm OF COVER

TANK:

10M @ 300mm O/C E/W

LID:

10M @ 300mm O/C E/W
CORNER BARS AROUND RISERS

WEIGHT:

LID APPROX. 9531 LBS/ 4332 KG
TANK APPROX. 18146 LBS/ 8248 KG
ASSEMBLED APPROX. 27677 LBS/ 12580 KG

NOTES:

JOINT SEALANT IS MASTIC SEALANT (CONSEAL CS-102)
(NSF APPROVED SEALANT AVAILABLE FOR POTABLE WATER HOLDING TANKS)
TANK ASSEMBLED ON SITE
SEE INSTRUCTIONS FOR ASSEMBLY PROCEDURES
1.5M MAXIMUM BURIAL
INLETS ARE 4" POLYLOK PIPE SEAL
LID AND RISER ARE 24" DIAMETER POLYLOK



58 COOPER ROAD
ROSSLYN, ONT.
Phone: (807) 939-2655
Fax: (807) 939-1788

PRODUCT

3000 GAL/ 13670 L
HOLDING TANK

JOB/PRODUCT CODE:

3000HTPR

CONTRACTOR:

SCALE:

N.T.S

DATE	INI.	DESCRIPTION
NOV 2013	MH	ORIGINAL DRAWING